



BROKIS®



# SFERA PORTABLE

CM14142

SMALL, LARGE - PC1271, PC1273

# INSTALLATION MANUAL

SFERA

Table light, Floor light, Battery light



## COMPONENTS INCLUDED WITH UNIT:

1× assembled light  
1× charging cable USB-C  
1× pair cotton gloves  
1× installation manual

## WARNING:

**The manufacturer assumes no liability for damage resulting from incorrect assembly.**

**When unpacking the light, do so with regard for its material composition – the main components are made of glass.**

**Wear the cotton gloves included with the light when unpacking and assembling it.**

**Installation time: 5 minutes / 1 person**



BROKIS®

BROKIS S.R.O.  
ŠPANILOVA 1315/25  
163 00 PRAHA 6 - ŘEPY  
CZECH REPUBLIC

ORG. ID 64940799  
VAT ID CZ64940799  
C 42174 MĚSTSKÝ SOUD  
V PRAZE

TEL +420 567 211 517  
TECHNICAL@BROKIS.CZ  
INFO@BROKIS.CZ  
WWW.BROKIS.CZ



### CLEANING THE GLASS

**BROKIS upholds only the highest possible quality standards. Prior to shipping, the light undergoes several quality controls and stages of cleaning. Because transportation, storage, and the amount of time that passes between packing at our plant and subsequent unpacking by the client can affect the light in different ways, we strongly recommend cleaning it prior to assembly.**

**The glass must first be rinsed in warm water, and a dish detergent may be used to remove all foreign particles, dust, and grease. Repeat the process if necessary and then dry the glass thoroughly with a paper towel.**

**Recommendation: Do not use mineral spirits, highly concentrated thinners, or other substances not intended for use on glass surfaces. Do not use any cleaning agents containing silicone, as they may leave a film and attract dust and smudges.**

**PRIOR TO SHIPPING, THE FUNCTIONALITY OF EACH LIGHT AND ITS COMPONENTS IS THOROUGHLY TESTED. THE MANUFACTURER ASSUMES NO LIABILITY FOR THE MISHANDLING OF PRODUCTS.**



## 1. SWITCHING THE LIGHT ON/OFF AND DIMMING

Switch on the light and check its functionality.

The light is switched on by touching the metal button on the concrete fixture.

The same method is used to increase or decrease brightness, which has three levels.

**WARNING:**

**ALWAYS PRESS THE METAL BUTTON GENTLY. EXCESSIVE FORCE MAY CAUSE DAMAGE.**

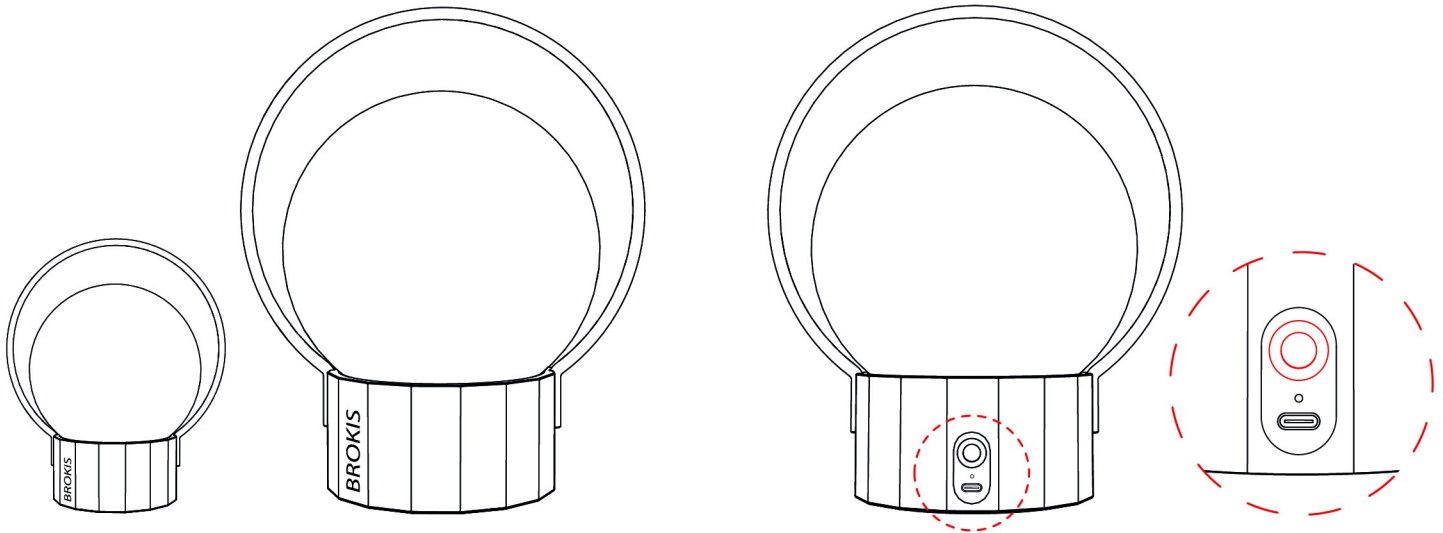

## 2. CHARGING THE LIGHT VIA THE USB-C CONNECTOR

Use the supplied charging cable to charge the light by inserting the USB-C connector into the light. The light is charging when the red LED is on. When the green LED comes on, the light is fully charged.

Charging time to 100 %: 4 hours.

Lighting time: 6 hours.

Recommended charging adapter: 5V/2A max.

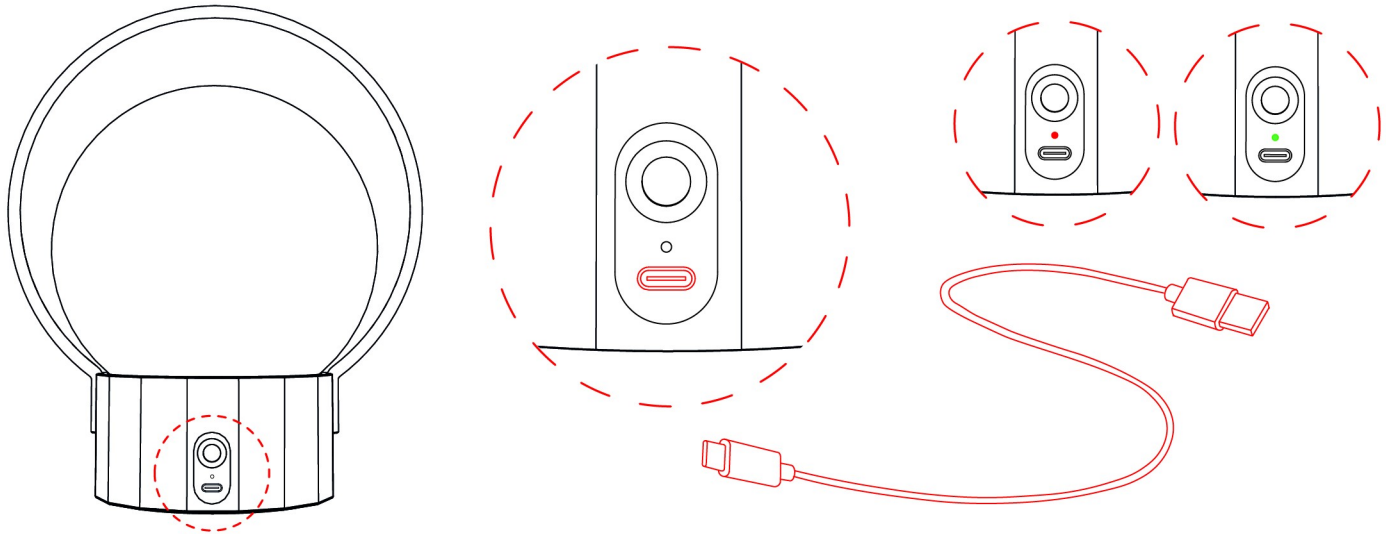

### 3. CHARGING THE LIGHT VIA WIRELESS SYSTEM (INDUCTION)

Place the light on the wireless charger.

The light is charging when the red LED is on. When the green LED comes on, the light is fully charged.

INDUCTION CHARGER NOT INCLUDED WITH LIGHT.

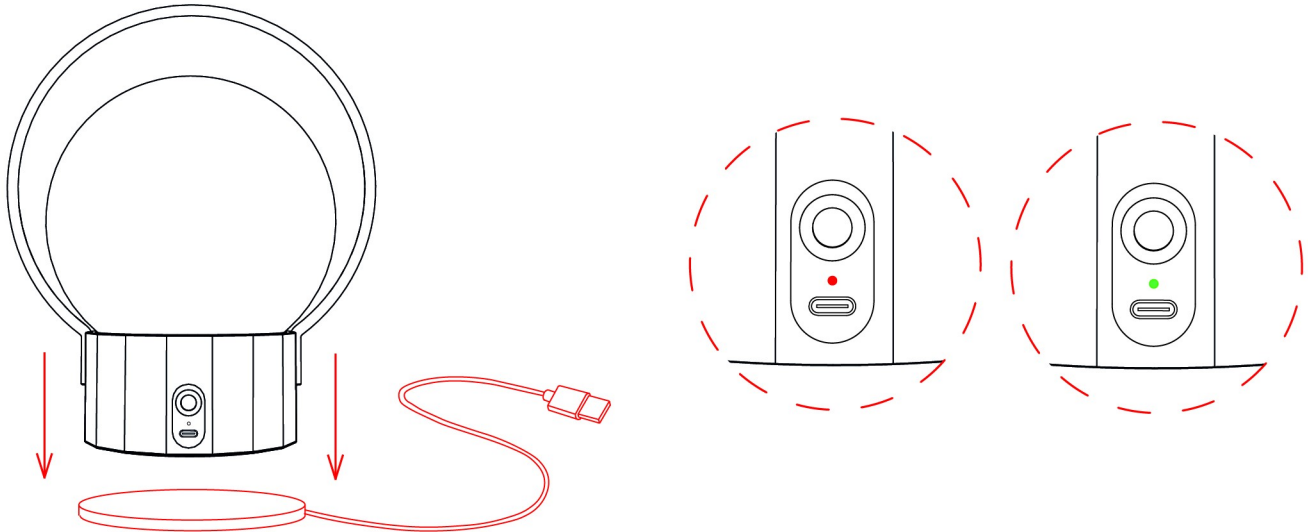

#### 4. DISASSEMBLY 1/2

When disassembling and subsequently reassembling the light, wear cotton gloves to prevent damage. Carefully place the light on its side on a blanket so that the metal ring is parallel with the surface of the blanket. On the underside of the concrete fixture, loosen the screws with a screwdriver (not included with light). Then remove the screws from the concrete fixture.

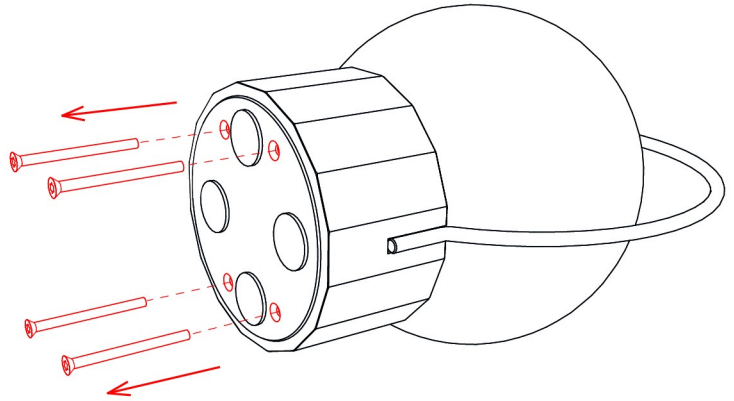
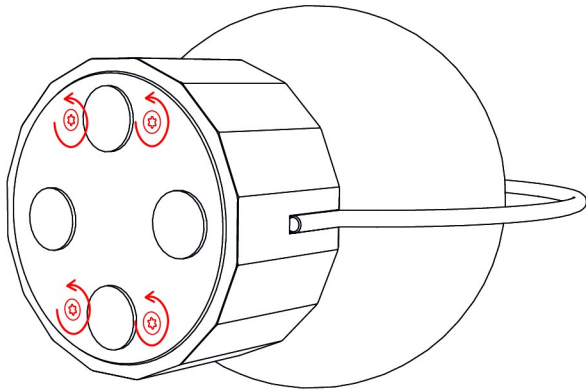

## 5. DISASSEMBLY 2/2

Carefully slide the glass shade out in the direction of the metal ring and then remove it.

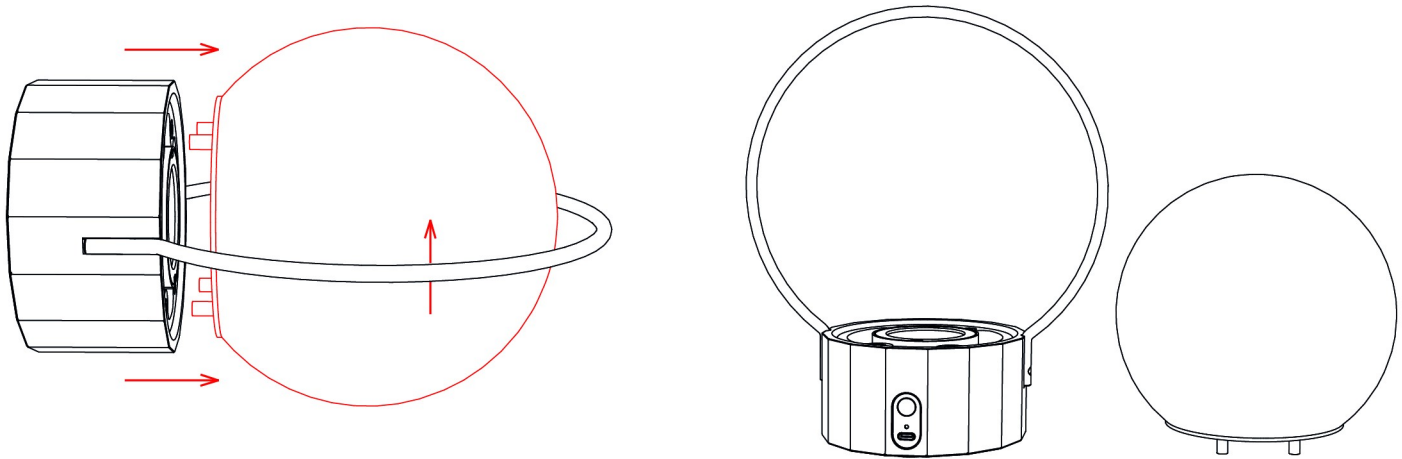

## 6. ASSEMBLY 1/2

Carefully insert the glass shade into the space within the metal ring and then slide the legs into the openings in the concrete fixture.

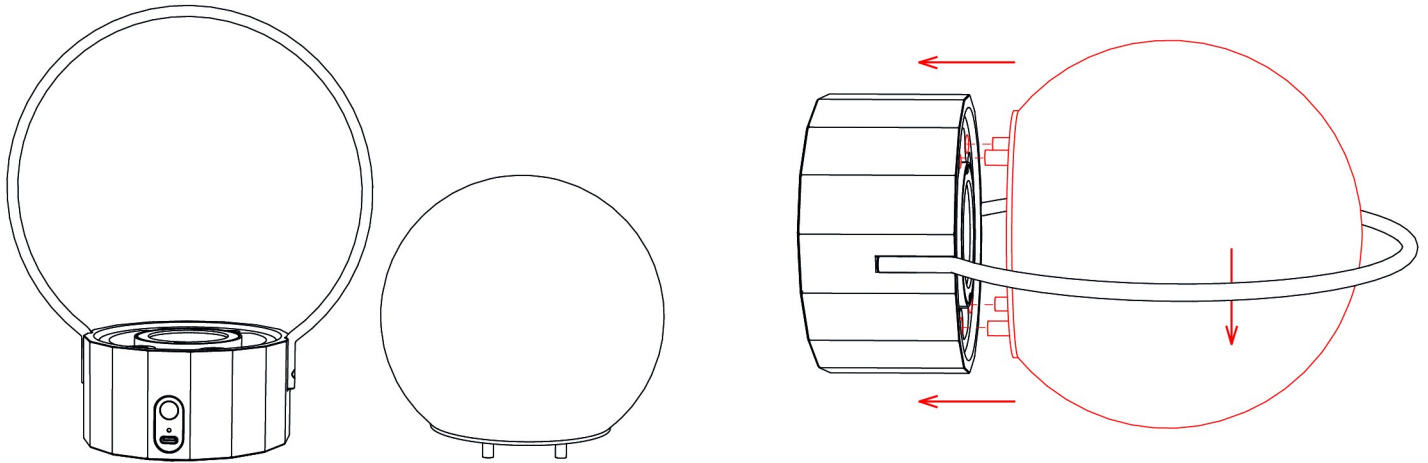

## 7. ASSEMBLY 2/2

Insert the screws into the openings on the underside of the concrete fixture and then tighten them with a screwdriver.

