

## SPECIFICATIONS

LED Flat Panel : 2.2 Watt  
(2700K-2200K) Warm Dim

150 Lumens

23-230 hr battery life

6 hr charge time (power plug not included: recommend 10W)

IP54 Damp Rating - NOTE! THIS RATING ONLY APPLIES WHEN SILICONE PLUG IS INSERTED INTO THE CHARGING PORT.

This device complied with part 15 of the FCC Rules. Operation is subject to the following two conditions: (1) This device may not cause harmful interference, and (2) this device must accept any interference received, including interference that may cause undesired operation.

**Caution: Changes or modifications to this unit not expressly approved by the party responsible for compliance could void the user's authority to operate the equipment.**

This device contains licence-exempt transmitter(s)/receiver(s) that comply with Innovation, Science and Economic Development Canada's licence-exempt RSS(s). Operation is subject to the following two conditions:

1. This device must not cause interference
2. This device must accept any interference, including interference that may cause undesired operation of this device.

*L'émetteur/récepteur exempt de licence contenu dans le présent appareil est conforme aux CNR d'Innovation, Sciences et Développement économique Canada applicables aux appareils radio exempts de licence. L'exploitation est autorisée aux deux conditions suivantes:*

1. *L'appareil ne doit pas produire de brouillage;*
2. *L'appareil doit accepter tout brouillage radioélectrique subi, même si le brouillage est susceptible d'en compromettre le fonctionnement.*

NOTE: This equipment has been tested and found to comply with the limits for a Class B digital device, pursuant to part 15 of the FCC Rules. These limits are designed to provide reasonable protection against harmful interference in a residential installation. This equipment generates, uses and can radiate radio frequency energy and, if not installed and used in accordance with the instructions, may cause harmful interference to radio communications. However, there is not guarantee that interference will not occur in a particular installation. If this equipment does cause harmful interference to radio or television reception, which can be determined by turning the equipment off and on, the user is encouraged to try to correct the interference by one of more of the following measures:

- Reorient or relocate the receiving antenna.
- Increase the separation between the equipment and receiver.
- Connect the equipment into an outlet on a circuit different from that to which the receiver is connected.
- Consult the dealer or an experienced radio/TV technician for help.

Pablo®

# LUCI TABLE

## USER GUIDE

Pablo®

INFO@PABLODESIGNS.COM  
INFO@PABLODESIGNS.EU

888 MARIN ST  
SAN FRANCISCO, CA  
94124

PABLODESIGNS.COM  
PABLODESIGNS.EU

INFO@PABLODESIGNS.COM  
888 MARIN STREET  
SAN FRANCISCO, CA  
94124

PABLODESIGNS.COM



# Pablo

## LUCI TABLE

### CONTENTS

- A. USB CHARGING CABLE
- B. LAMP HEAD
- C. LAMP BODY
- D. STABILITY PLATE
- E. SILICONE CHARGE PORT PLUG

NOTE! IP54 RATING ONLY APPLIES WHEN SILICONE PLUG IS INSERTED INTO THE CHARGING PORT.

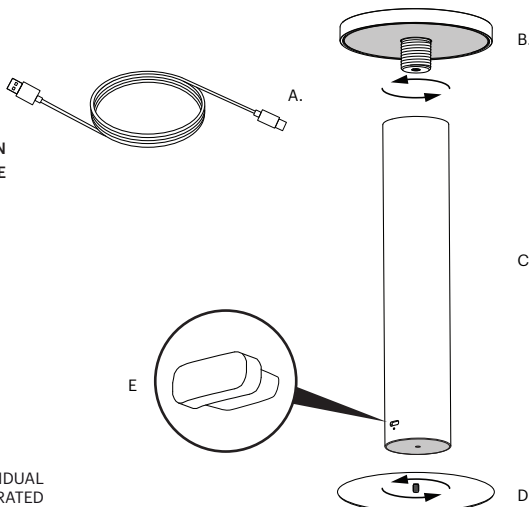

### ASSEMBLY

REMOVE ALL COMPONENTS FROM INDIVIDUAL PACKAGING AND JOIN IN ORDER DEMONSTRATED HERE. NOTE: STABILITY PLATE IS OPTIONAL.

### FUNCTION

**3-STAGE TOUCH SWITCH**  
TAP SWITCH BRIEFLY TO CYCLE THROUGH; 100%, 40%, 10%, AND OFF.

**USB-C CHARGE PORT**  
+ INDICATOR LIGHT

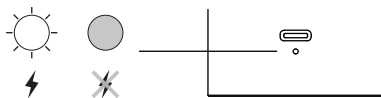

STANDBY	OFF
BATTERY LOW (BELOW 20%)	ON
CHARGING (0-90%)	FLASHING SLOWLY
CHARGING (90-100% COMPLETE)	ON

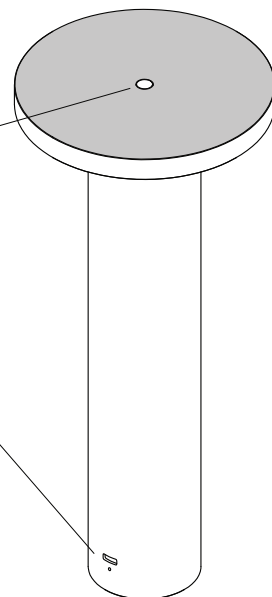

### DE: INHALT

- A. USB-LADEKABEL
- B. LAMPENKOPF
- C. LAMPENGEHÄUSE
- D. STABILITÄTSPLATTE

### MONTAGE

ALLE KOMPONENTEN AUS DER EINZELNEN VERPACKUNG ENTNEHMEN UND IN DER HIER DEMONSTRIERTEN REIHENFOLGE VERBINDEN. HINWEIS: STABILITÄTSPLATTE IST OPTIONAL.

### FUNKTION

#### KAPAZITIVE STEUERUNG MIT VIER STUFEN

BERÜHREN SIE SCHALTER, UM DURCHZYKLIEREN. 100%, 40%, 20%, 3% UND AUS.

#### USB-C-LADEPORT

23 - 230 STUNDEN AKKULAUFZEIT

6 STD. LADEZEIT (NETZSTECKER NICHT IM LIEFERUMFANG ENTHALTEN: EMPFOHLEN 10 W)

#### SPEZIFIKATIONEN

WARM DUNKEL LED (2700-2200K)

2.2 WATT

150 LUMENS

IP54-FEUCHTIGKEITSKLASSE - HINWEIS!  
DIESE BEWERTUNG GILT NUR, WENN DER SILIKONSTECKER IN DEN LADEANSCHLUSS EINGESTECKT IST.

#### KONTROLLEUCHTE

BEREITHALTEN	AUS
NIEDRIGER BATTERIESTATUS (UNTEN 20%)	AUF
LADEN (0-90%)	BLINKT LANGSAM
LADEN (90-100% VOLLSTÄNDIG)	AUF

### FR: CONTENU

- A. CÂBLE DE CHARGE USB
- B. TÊTE DE LAMPE
- C. CORPS DE LAMPE
- D. PLAQUE DE STABILITÉ

### ASSEMBLÉE

RETIREZ TOUS LES COMPOSANTS DE L'EMBALLAGE INDIVIDUEL ET REJOIGNEZ-LES DANS L'ORDRE DÉMONTRÉ ICI. REMARQUE : LA PLAQUE DE STABILITÉ EST EN OPTION.

### FONCTION

#### INTERRUTTORE A QUATTRO STADI

TOCCA BREVE L'INTERRUTTORE PER CICLARE ATTRAVERSO; 100%, 40%, 20%, 3% E SCONTO.

#### PORT DE CHARGE USB-C

AUTONOMIE DE 23 À 230 HEURES

TEMPS DE CHARGE DE 6 HEURES (PRISE D'ALIMENTATION NON INCLUSE : 10 W RECOMMANDÉ)

#### CARACTÉRISTIQUES

CHAUD DIM LED (2700-2200K)

2.2 WATT

150 LUMENS

INDICE D'HUMIDITÉ IP54 - REMARQUE !  
CETTE ÉVALUATION S'APPLIQUE  
UNIQUEMENT LORSQUE LA FICHE EN  
SILICONE EST INSÉRÉE DANS LE PORT  
DE CHARGE.

#### VOYANT

DE RÉSERVE	DÉSACTIVÉ
BATTERIE FAIBLE (INFÉRIEURE À 20%)	ACTIVE
CHARGE (0-90%)	CLIGNOTANT LENTEMENT
CHARGE (90-100%)	ACTIVE

### IT: CONTENUTI

- A. CAVO DI RICARICA USB
- B. TESTA DELLA LAMPADA
- C. CORPO LAMPADA
- D. PIASTRA DI STABILITÀ

### MOTAGGIO

RIMUOVERE TUTTI I COMPONENTI DALL'IMBALLAGGIO SINGOLO E UNISCITI NELL'ORDINE DIMOSTRATO QUI.

NOTA: LA PIASTRA DI STABILITÀ È FACOLTATIVA.

### FUNZIONE

#### INTERRUTTORE A QUATTRO STADI

TOCCA BREVE L'INTERRUTTORE PER CICLARE ATTRAVERSO; 100%, 40%, 20%, 3% E SCONTO.

#### PORTA DI RICARICA USB-C

23-230 ORE DI DURATA DELLA BATTERIA

TEMPO DI RICARICA DI 6 ORE (SPINA DI ALIMENTAZIONE NON INCLUSA: CONSIGLIA 10 W)

#### SPECIFICHE

CALDO FIOCO LED (2700-2200K)

2.2 WATT

150 LUMENS

GRADO DI UMIDITÀ IP54 - NOTA!  
QUESTA VALUTAZIONE SI APPLICA  
SOLO QUANDO LA SPINA IN  
SILICONE È INSERITA NELLA P  
ORTA DI RICARICA.

#### SPIA

LA RISERVA	SPENTA
BATTERIA SCARICA (INFERIORE AL 20%)	ATTIVA
RICARICA (0-90%)	LAMPEGGIANTE LENTAMENTE
RICARICA (90-100%)	ATTIVA

## SPECIFICATIONS

LED Flat Panel : 5.3 Watt  
(2700K-2200K) Warm Dim  
350 Lumens  
11-110 hr battery life  
5 hr charge time (using provided 24W power adapter)  
**IP54 Damp Rating - NOTE! THIS RATING ONLY APPLIES WHEN SILICONE PLUG IS INSERTED INTO THE CHARGING PORT.**

This device complied with part 15 of the FCC Rules. Operation is subject to the following two conditions: (1) This device may not cause harmful interference, and (2) this device must accept any interference received, including interference that may cause undesired operation.

**Caution: Changes or modifications to this unit not expressly approved by the party responsible for compliance could void the user's authority to operate the equipment.**

This device contains licence-exempt transmitter(s)/receiver(s) that comply with Innovation, Science and Economic Development Canada's licence-exempt RSS(s). Operation is subject to the following two conditions:  
1. This device must not cause interference  
2. This device must accept any interference, including interference that may cause undesired operation of this device.

*L'émetteur/récepteur exempt de licence contenu dans le présent appareil est conforme aux CNR d'Innovation, Sciences et Développement économique Canada applicables aux appareils radio exempts de licence. L'exploitation est autorisée aux deux conditions suivantes:*

- 1. L'appareil ne doit pas produire de brouillage;*
- 2. L'appareil doit accepter tout brouillage radioélectrique subi, même si le brouillage est susceptible d'en compromettre le fonctionnement.*

NOTE: This equipment has been tested and found to comply with the limits for a Class B digital device, pursuant to part 15 of the FCC Rules. These limits are designed to provide reasonable protection against harmful interference in a residential installation. This equipment generates, uses and can radiate radio frequency energy and, if not installed and used in accordance with the instructions, may cause harmful interference to radio communications. However, there is not guarantee that interference will not occur in a particular installation. If this equipment does cause harmful interference to radio or television reception, which can be determined by turning the equipment off and on, the user is encouraged to try to correct the interference by one of more of the following measures:

- Reorient or relocate the receiving antenna.
- Increase the separation between the equipment and receiver.
- Connect the equipment into an outlet on a circuit different from that to which the receiver is connected.
- Consult the dealer or an experienced radio/TV technician for help.

Pablo®

LUCI FLOOR

## USER GUIDE

Pablo®

INFO@PABLODESIGNS.COM  
INFO@PABLODESIGNS.EU

888 MARIN ST  
SAN FRANCISCO, CA  
94124

PABLODESIGNS.COM  
PABLODESIGNS.EU

INFO@PABLODESIGNS.COM  
888 MARIN STREET  
SAN FRANCISCO, CA  
94124

PABLODESIGNS.COM



## CONTENTS

- A. UPPER POST SECTION
- B. LOWER POST SECTION
- C. LAMP HEAD
- D. LAMP BASE
- E. POWER SUPPLY UNIT  
(GLOBAL PIN ADAPTERS INCLUDED)
- F. SILICONE CHARGE PORT PLUG

NOTE! IP54 RATING ONLY APPLIES WHEN SILICONE PLUG IS INSERTED INTO THE CHARGING PORT.

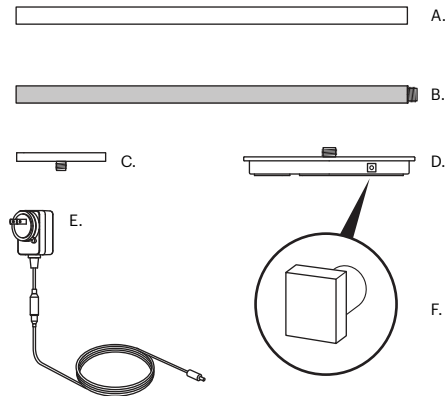

## ASSEMBLY

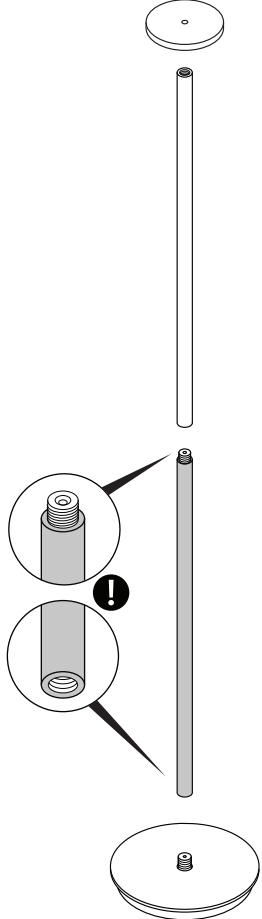

## FUNCTION

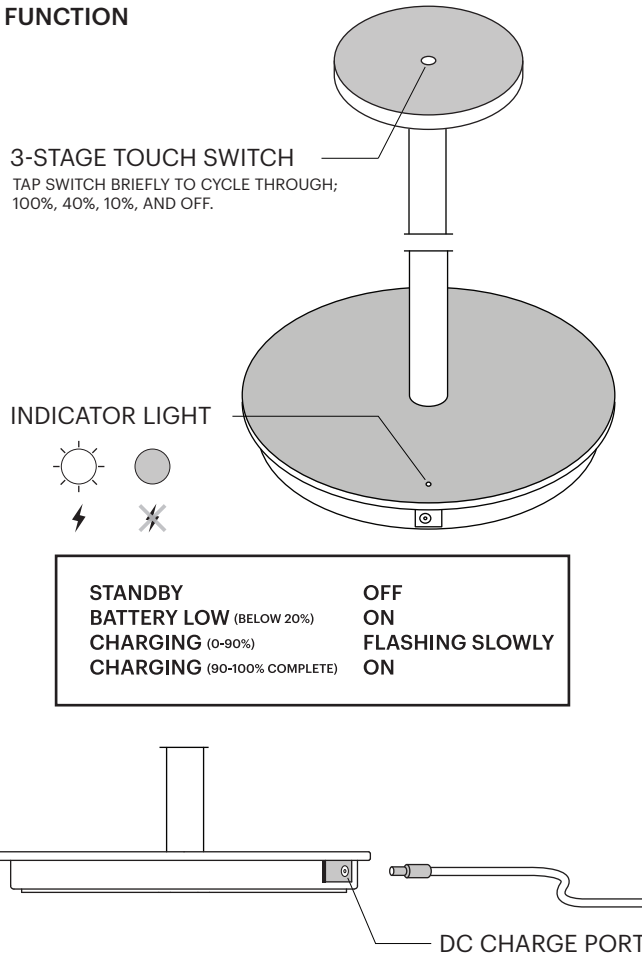

## DE: INHALT

- A. OBERER PFOSTENABSCHNITT
- B. UNTERER PFOSTENABSCHNITT
- C. LAMPENKOPF
- D. LAMPENFUSS
- E. NETZTEIL (GLOBAL PIN ADAPTER ENTHALTEN)

## FUNKTION

### DREISTUFIGER TOUCH-SCHALTER

TIPPEN SIE DEN SCHALTER KURZ, UM DURCHZUSCHALTEN; 100%, 40%, 10% UND AUS.

### KONTROLLEUCHE

BEREITHALTEN	AUS
NIEDRIGER BATTERIESTATUS (UNTEN 20%)	AUF
LADEN (0-90%)	BLINKT LANGSAM
LADEN (90-100% VOLLSTÄNDIG)	AUF

### SPEZIFIKATIONEN

5.3 WATT - WARM DUNKEL LED (2700-2200K)  
350 LUMENS

11 - 110 STUNDEN AKKULAUFZEIT

5 STUNDEN LADEZEIT (UNTER VERWENDUNG DES MITGELIEFERTEN 24-W-NETZTEILS)

IP54-FEUCHTIGKEITSKLASSE - HINWEIS! DIESE BEWERTUNG GILT NUR, WENN DER SILIKONSTECKER IN DEN LADEANSCHLUSS EINGESTECKT IST.

## FR: CONTENU

- A. SECTION DE POTEAU SUPÉRIEUR
- B. SECTION INFÉRIEURE DU POTEAU
- C. TÊTE DE LAMPE
- D. BASE DE LAMPE
- E. BLOC D'ALIMENTATION (ADAPTATEURS GLOBAL PIN INCLUS)

## FONCTION

### INTERRUPTEUR TACTILE À TROIS ÉTAPES

APPUYEZ BRIÈVEMENT SUR L'INTERRUPTEUR POUR FAIRE CYCLE ; 100 %, 40 %, 10 % ET ARRÊT.

### VOYANT

DE RÉSERVE	DÉSACTIVÉ
BATTERIE FAIBLE (INFÉRIEURE À 20%)	ACTIVE
CHARGE (0-90%)	CLIGNOTANT LENTEMENT
CHARGE (90-100%)	ACTIVE

### CARACTÉRISTIQUES

5.3 WATT - CHAUD DIM LED (2700-2200K)  
350 LUMENS

AUTONOMIE DE 11 À 110 HEURES

TEMPS DE CHARGE DE 5 HEURES (AVEC L'ADAPTATEUR SECTEUR 24 W FOURNI)

INDICE D'HUMIDITÉ IP54 - REMARQUE ! CETTE ÉVALUATION S'APPLIQUE UNIQUEMENT LORSQUE LA FICHE EN SILICONE EST INSÉRÉE DANS LE PORT DE CHARGE.

## IT: CONTENUTI

- A. SEZIONE MONTANTE SUPERIORE
- B. SEZIONE POSTA INFERIORE
- C. TESTA DELLA LAMPADA
- D. BASE DELLA LAMPADA
- E. UNITÀ DI ALIMENTAZIONE (ADATTATORI PIN GLOBALI INCLUSI)

## FUNZIONE

### INTERRUTTORE TOUCH A TRE STADI

TAP INTERRUTTORE BREVEMENTE PER CICLA ATTRAVERSO; 100%, 40%, 10% E OFF.

### SPIA

LA RISERVA	SPENTA
BATTERIA SCARICA (INFERIORE AL 20%)	ATTIVA
RICARICA (0-90%)	LAMPEGGIANTE LENTAMENTE
RICARICA (90-100%)	ATTIVA

### SPECIFICHE

5.3 WATT - CALDO FIOCO LED (2700-2200K)  
350 LUMENS

11-110 ORE DI DURATA DELLA BATTERIA

TEMPO DI RICARICA DI 5 ORE (UTILIZZANDO L'ADATTATORE DI ALIMENTAZIONE DA 24 W IN DOTAZIONE)

GRADO DI UMIDITÀ IP54 - NOTA! QUESTA VALUTAZIONE SI APPLICA SOLO QUANDO LA SPINA IN SILICONE È INSERITA NELLA PORTA DI RICARICA.