

# Can Wall Structure

20 60 120

### Material care

Barro negro - Use a soft clean cloth or a vacuum with a clean brush attachment, do not wipe wet.

Powder coated Aluminum - Dust gently with a duster or soft rag. Do not use commercial cleaners.  
Avoid abrasive cleaning agents.

### Cuidado del material

Barro negro- Use un paño limpio o aspirelo con un cepillo suavemente.  
No use tramp humedo.

Metal - Retire el polvo suavemente con un plumero o un trapo suave y seco.  
No utilice limpiadores comerciales.  
Evite los agentes de limpieza abrasivos.

## Parts included

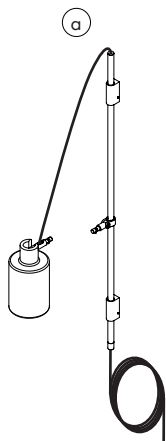

a- barro negro + wall mounting.

b- tube (20 cm). Only for the 20 cm model

c- tube (60 cm). Only for the 60 cm model

d- tubes (2x60 cm). Only for the 120 cm model

e- wall cable fixation.

f- allen key set.

g- solid wall installation set.

h- drywall installation set.

## Partes incluidas

a- barro negro + montaje de muro.

b- tubo (20cm). Solo pra modelo de 20cm

c- tubo (60cm). Solo pra modelo de 60cm

d- tubo (120cm). Solo pra modelo de 120cm

e- fijacion de cable a pared.

f- juego de llaves allen.

g- kit de instalación para muro sólido.

h- kit de instalación para tablaroca.

## Notes before assembly



We recommend reading the complete assembly manual before starting the installation.

Disconnect the power by turning off the circuit breaker, or by removing the fuse in the fuse box before assembling and mounting.

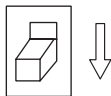

Use gloves provided at any time of the installation



Two people are needed for installation.

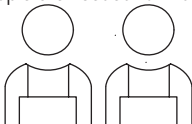

Be careful when unpacking the product to avoid damaging any of the elements. We recommend placing it on a protective surface such as a cardboard or a blanket.

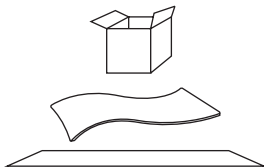

## Notas antes del montaje



Recomendamos leer el manual de montaje completo antes de iniciar la instalación.

Desconecte la alimentación bajando la pastilla o quitando el fusible de la caja de fusibles antes de ensamblar y montar.

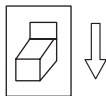

Utilice los guantes proporcionados en cualquier momento de la instalación.



Se necesitan dos personas para la instalación.

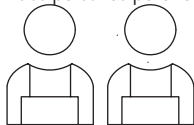

Tenga cuidado al desempacar este producto para no dañar ninguno de los elementos. Recomendamos colocarlo sobre una superficie protectora como un cartón o una manta y el uso de un par de guantes(incluidos)

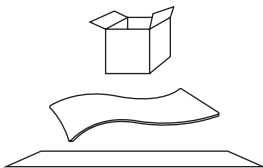

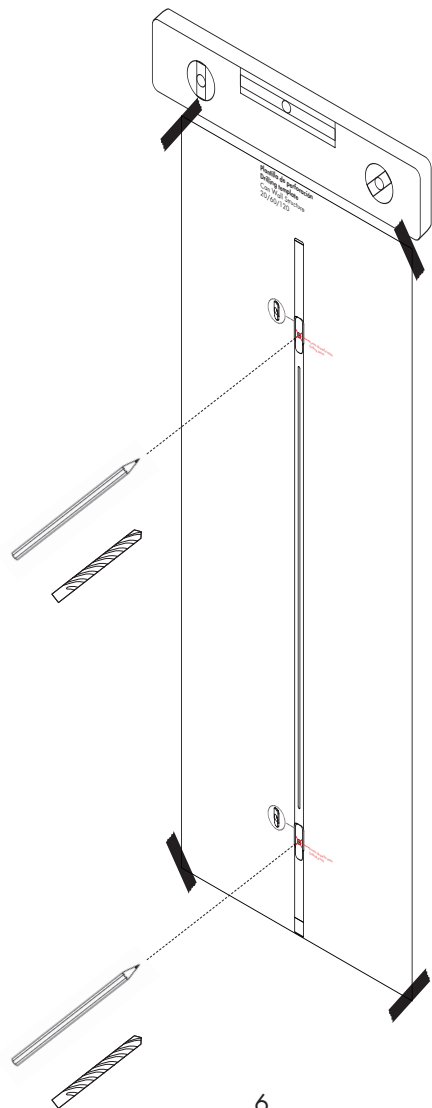



Place the included sheet of paper between the product and the wall to prevent scratching during installation.

Añada una pieza de papel (incluida) entre el producto y el muro para evitar rayaduras durante la instalación.

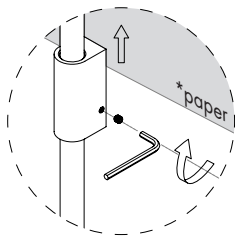
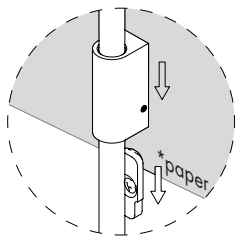
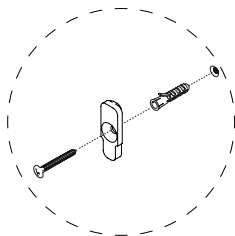
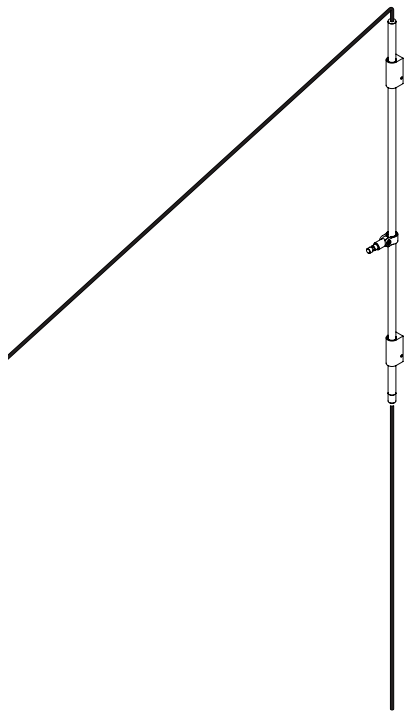

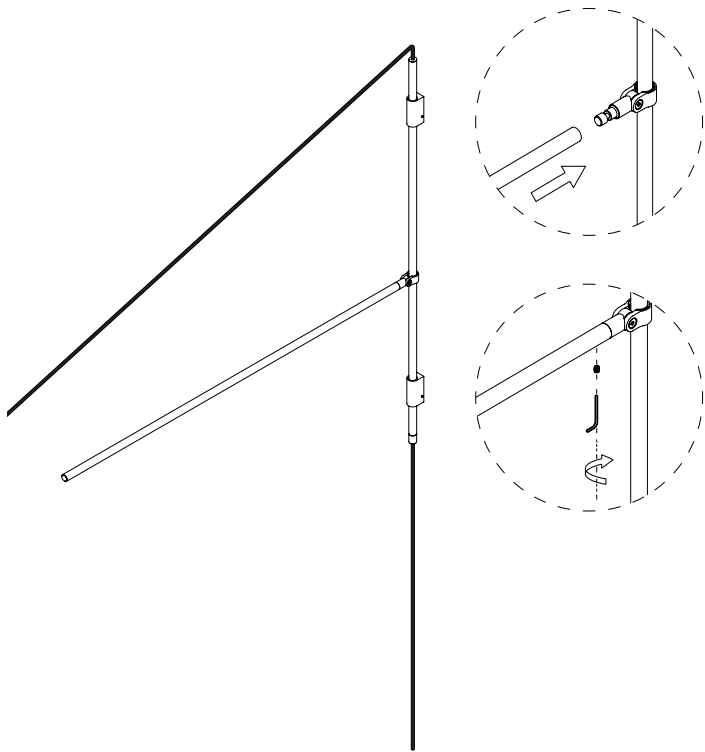



This step is only for the 120 cm model.

Este paso es solamente para el modelo de 120 cm.

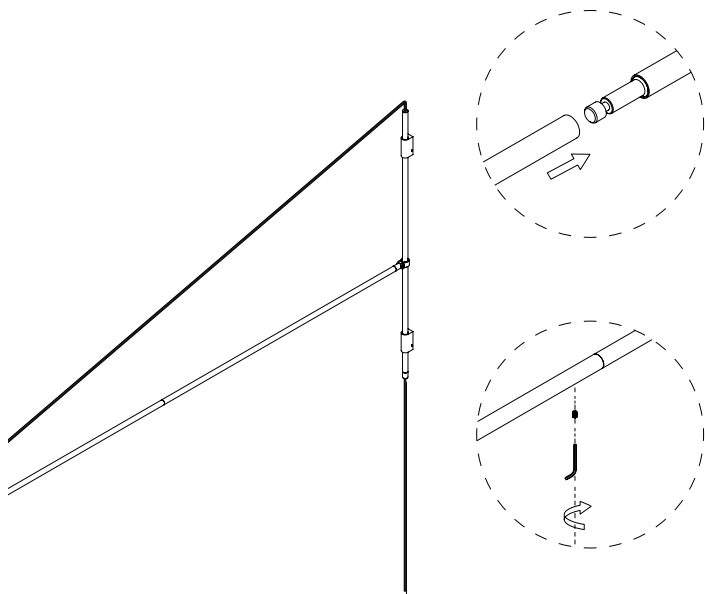

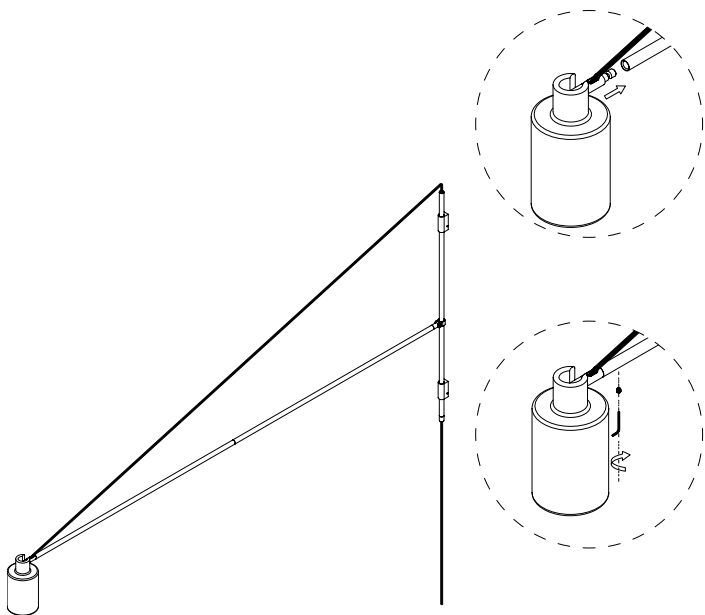



Turn counterclockwise to adjust the height, then tighten to lock the horizontal post height in place.

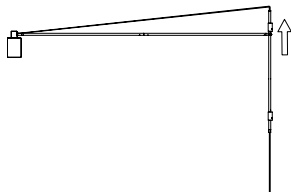
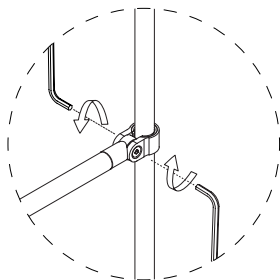
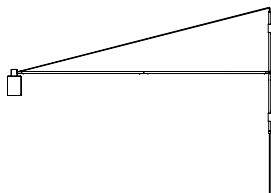
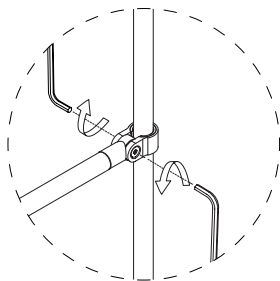
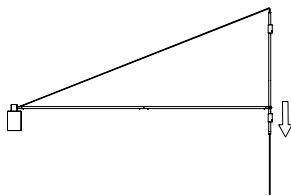



To adjust the inclination and height, align the mechanism with the adjuster located at the bottom of the fixed tube.

Para ajustar la inclinación y la altura, alinee el mecanismo con el ajustador ubicado en la parte inferior del tubo fijo.

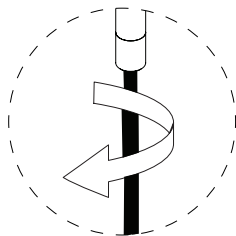
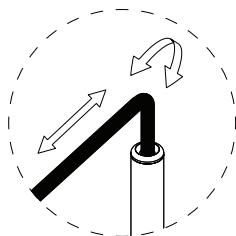
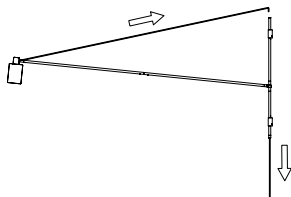
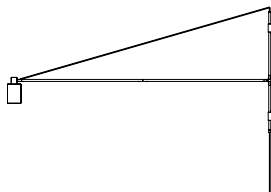
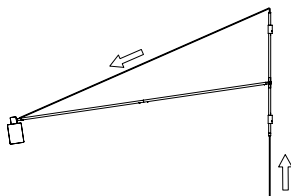



Insert the cable through the gap, then rotate to secure it in the place.

Inserte el cable a través del espacio, rote para asegurar en su posición.

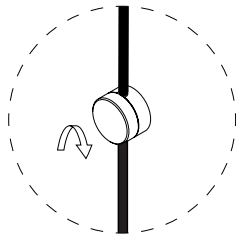
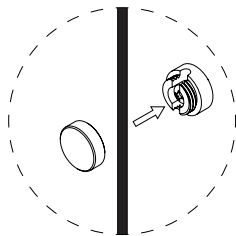
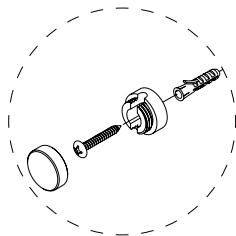
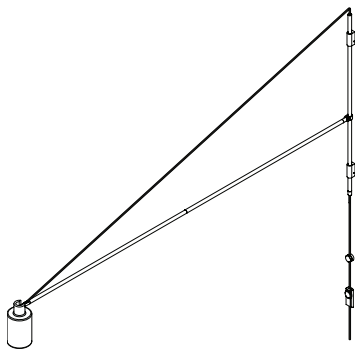

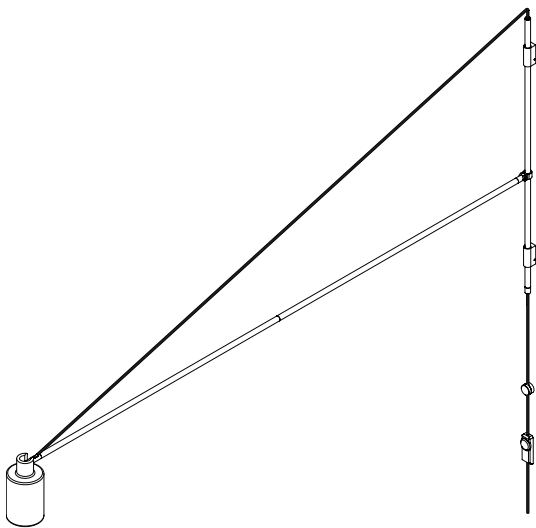



Bulb Change

Cambio de bombilla

